

# VERSAFITCUP® CC TRIO FAMILY

ELLIPTICAL PRESS-FIT CUP

ENHANCE YOUR OPTIONS



## Surgical Technique

Joint

Spine

Sports Med



## TABLE OF CONTENTS

<b>1. INTRODUCTION</b>	<b>4</b>
1.1 Indications	4
1.2 Contraindications	4
1.3 Pre-operative planning	4
1.4 Surgical approach	4
<b>2. REAMING</b>	<b>5</b>
<b>3. TRIALS</b>	<b>6</b>
<b>4. IMPACTION OF THE ACETABULAR SHELL</b>	<b>7</b>
<b>5. PLUG AND SCREW FIXATION (OPTIONS)</b>	<b>8</b>
<b>6. STABILITY TEST</b>	<b>9</b>
<b>7. POSITIONING OF DEFINITIVE LINER</b>	<b>9</b>
7.1 Positioning of the definitive UHMWPE liner	9
7.2 Positioning of the definitive ceramic liner	11
<b>8. IMPLANTS NOMENCLATURE</b>	<b>12</b>

## 1. INTRODUCTION

The Versafitcup CC Trio Family is a range of cementless elliptical acetabular shell providing the choice between different shell sizes, liner shapes and materials.

The acetabular shell is available in two different versions: Versafitcup CC Trio with lateral screw holes and Versafitcup CC Trio No-Hole, without lateral holes.

The Versafitcup CC Trio Family and the Versafitcup DM constitute the Versafitcup System: a unique concept, which offers a complete product range for any requirement.

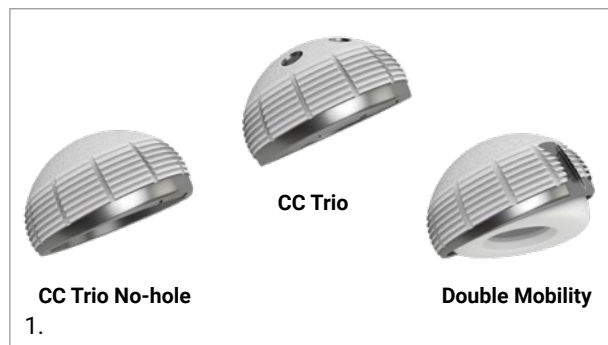

### 1.1 INDICATIONS

The Versafitcup CC Trio and the Versafitcup CC Trio No-Hole are designed for cementless use in total hip arthroplasty in primary or revision surgery. The patient should be skeletally mature. The patient's condition should be due to one or more of:

- Severely painful and/or disabled joint: as a result of osteoarthritis, post-traumatic arthritis, rheumatoid arthritis or psoriatic arthritis, Congenital hip dysplasia, Ankylosing spondylitis.
- Avascular necrosis of the femoral head.
- Acute traumatic fracture of the femoral head or neck.
- Failure of previous hip surgery: joint reconstruction, internal fixation, arthrodesis, hemiarthroplasty, surface replacement arthroplasty, or total hip replacement where sufficient bone stock is present.

### 1.2 CONTRAINDICATIONS

Total or partial hip replacement is contraindicated in the following cases:

- Acute, systemic or chronic infection.
- Muscular, neurological or vascular deficiency of the affected limb.
- Bone destruction, or loss of bone characteristics that may compromise the stability of the implant.
- Pathologies that may compromise the functionality of the implant in any way.

Mental or neuromuscular disorders may create an unacceptable risk to the patient and can be a source of postoperative complications. It is the surgeon's responsibility to ensure that the patient has no known allergy to the materials used.

### 1.3 PRE-OPERATIVE PLANNING

The goal is to determine the optimum acetabular implant size. Using the set of X-ray templates to the scale of 1.15:1 (with an X-ray of the same magnification) it will be possible to determine:

- The implant size.
- The ideal position of the acetabular shell for optimum coverage.

### WARNING

The final implant will be selected intra-operatively, because of possible discrepancies between actual conditions and templating. The choice will be determined by the size of the final reamer used and the trial cup tests.

### 1.4 SURGICAL APPROACH

The choice of surgical approach is up to the surgeon. The instrumentation has been developed for standard approach. Specific instrumentation for the anterior approach is available under request (for further information see the AMIS dedicated surgical technique).

## 2. REAMING

After performing an osteotomy of the femoral neck, expose and prepare the acetabular cavity and remove osteophytes.

Start reaming with the acetabular reamers.



The ideal reaming axis has an inclination of  $40^{\circ}/45^{\circ}$ , and an anteversion of  $15^{\circ}/20^{\circ}$  (anteversion recommended for posterior approaches).

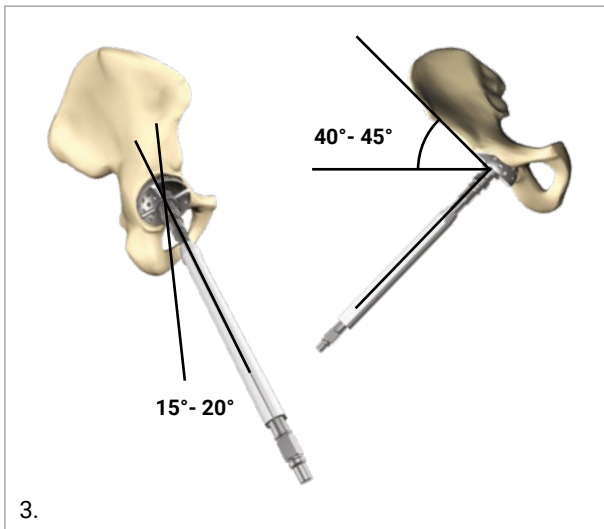

Reaming of the acetabulum starts with the smallest reamer and increases in increments of 2 mm, until a perfectly regular hemispherical cavity has been obtained, in the presence of bleeding subchondral bone. The preoperative plan can also be used as a reference.

### **WARNING**

During final reaming, avoid changing the reamer axis, in order not to make the prepared bed oval, which may affect or prevent primary seating of the implant.

As a general rule the right diameter corresponds to 4 or 6 mm greater than the femoral head diameter size.

Take care to retain, as far as possible, the bone stock up to the level of anterior and posterior columns.

Bone reamings may be saved for void filling between implant and acetabulum.

### 3. TRIALS

Assemble the trial cup with the same diameter of the last reamer onto the multifunction handle.

Insert the trial cup into the reamed cavity in order to estimate the depth and the orientation of the acetabular component.

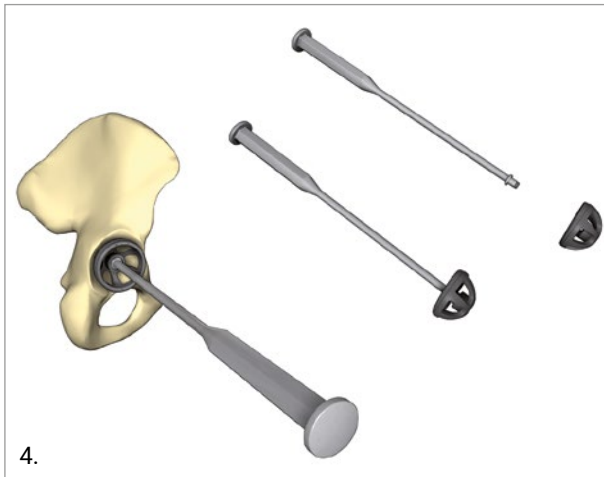

Trial cups:

- Are smooth and have the same dimensions as the reamers to avoid damaging the socket
- Are slightly undersized compared to the implant to allow a maximum press-fit effect with the definitive implant
- Have several openings to permit a direct view of the underlying acetabular surface.

Both reamers and trial cups are hemispherical, whereas the implants are elliptical and equatorially expanded, providing a good initial press-fit.

Both implant and trial cup have a 5° cranial edge. Marks on the trial cup and on the acetabular shell help to identify cranial edge top (see image).

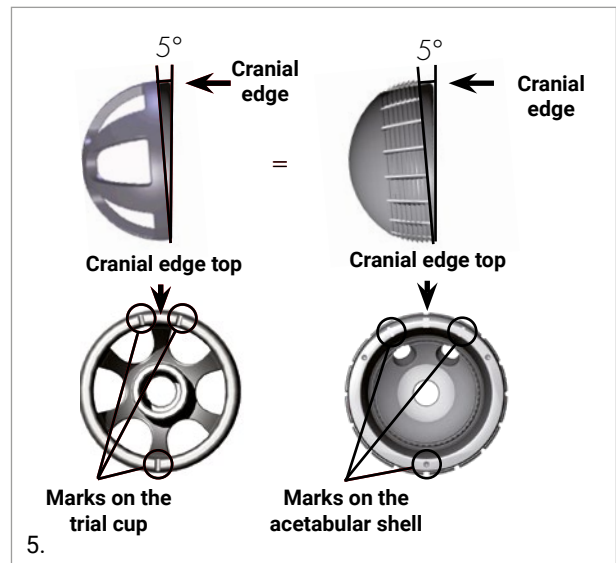

#### OPTION

In order to ensure the correct positioning of the definitive acetabular shell, use electrocautery to mark the cranial edge top.

#### TIP

If the trial cup is not stable or primary stability is doubtful, especially in the presence of poor bone quality, it is possible to choose a larger cup size, either with or without additional acetabular reaming.

## 4. IMPACTION OF THE ACETABULAR SHELL

After a satisfactory trial, the final acetabular shell can be positioned. The definitive acetabular shell size will be the same as the final trial cup size. However the acetabular shell is slightly oversized in order to allow a maximum press-fit.

Assemble the impactor handle with the acetabular shell until it is completely locked, in order not to damage the impactor screw thread during the impaction. Impact the implant at the desired angle of orientation into the prepared acetabulum.

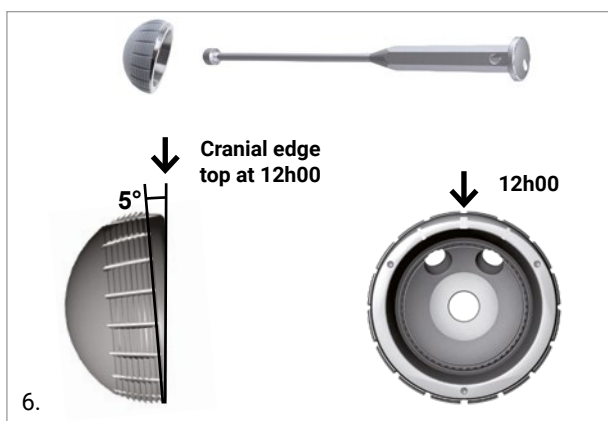

### OPTION

An orientation guide is available to aid in the acetabular shell positioning and to find satisfactory orientation tested during trials: the orientation guide will be positioned on the top of the impactor handle. The two rods are inclined at 45° and 20° to the handle.

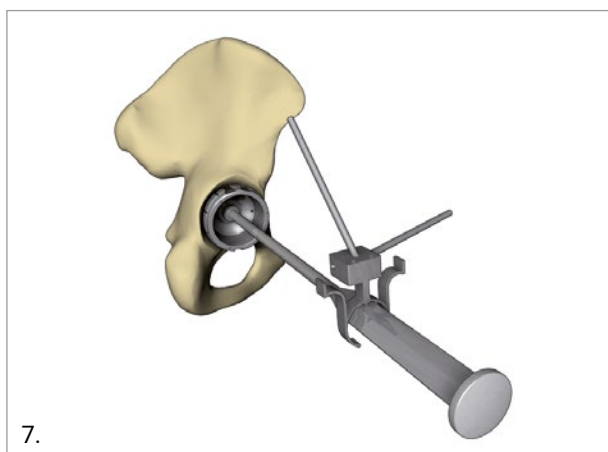

Impact the acetabular shell with the aid of a hammer, until it is completely stable.

### CAUTION

Never use the impactor handle after the impaction to reposition or rotate the acetabular shell, in order not to damage the threaded end. If needed, use only the acetabular shell correction impactor, assembled with the multifunction handle.

Remove the impactor handle.

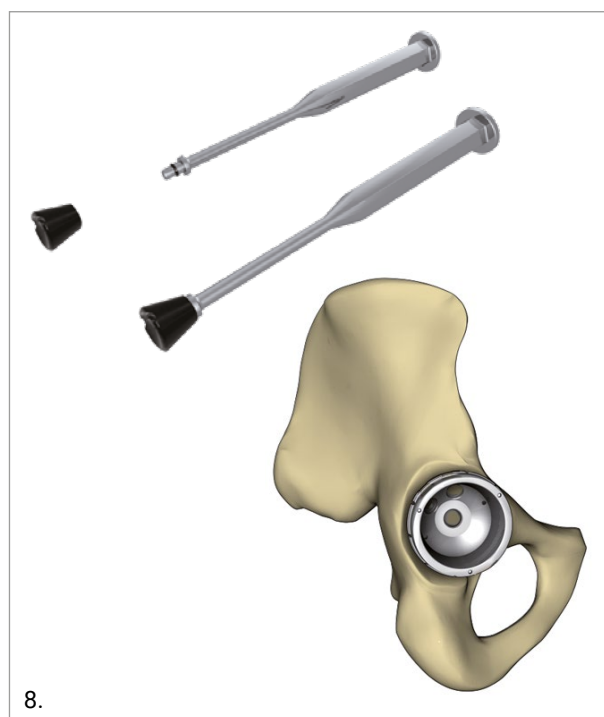

### CAUTION

After impaction of the acetabular shell, ensure osteophytes have been properly removed in order to avoid any impingement.

### TIP

In order to ensure the correct depth of the definitive acetabular shell, use the mark made during the test with the trial cup or use the holes to see the acetabulum floor. Because of the elliptical shape of the acetabular shell, it is normal to have a space between acetabular shell and acetabulum floor. This distance should be no deeper than 2 mm.

## 5. PLUG AND SCREW FIXATION (OPTIONS)

The Versafitcup CC Trio allows the surgeon to use cancellous bone screws to provide additional fixation.

These two screws should be located in the Posterior-Superior acetabular quadrant once final impaction is done, to minimize the potential for neurologic and vascular injury.

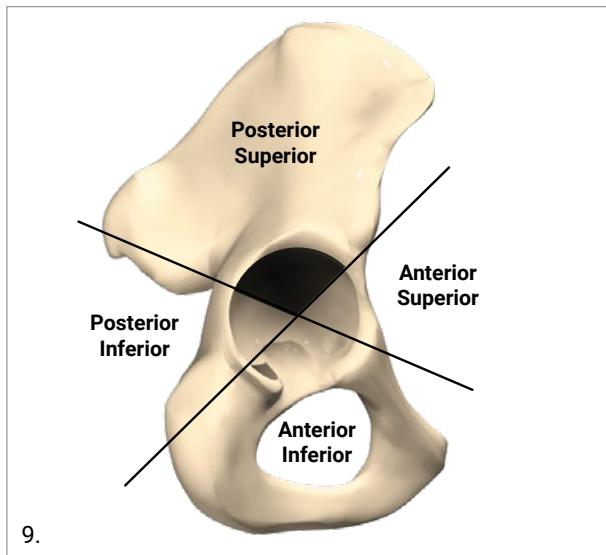

Drill through the acetabular shell hole using a Ø 3.2 mm drill bit with the help of a drill guide. If appropriate, a flexible shaft bit driver is available in order to facilitate the drilling procedure.

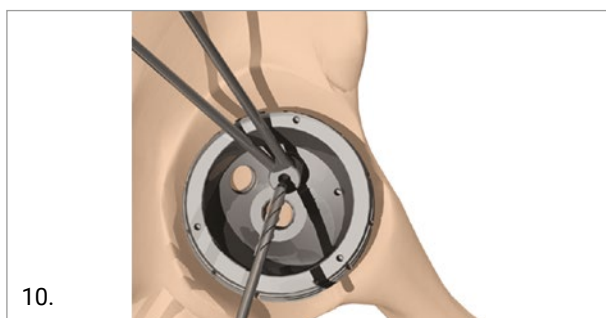

Two different screw versions are available:

- Cancellous Bone Screw Flat Head Ø 6.5 (01.26.65.20 - 01.26.65.45) offering a wider angular range.
- Cancellous Bone Screw Ø 6.5 (01.43.0015 - 01.43.0070) offering higher mechanical resistance.

### CAUTION

The Cancellous Bone Screw Ø 6.5 (01.43.0015 - 01.43.0070) requires a dedicated drill guide (01.10.10.372). Color coding has been introduced for easier identification. The dedicated drill guide has a gold colored tip and a gold colored band is present on the screw label.

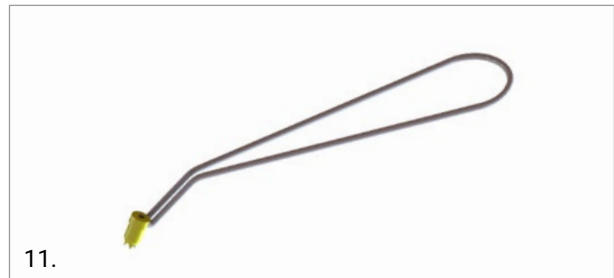

Use the hooked depth gauge in order to measure the drilling depth and select a self-tapping screw of appropriate length (with flat head and Ø 6.5 mm). Screwing is performed with the aid of a universal hexhead screwdriver.

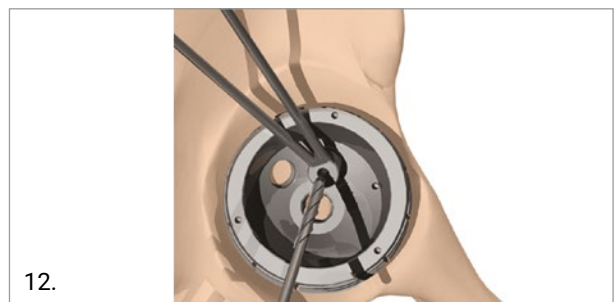

### CAUTION

Always use flat head screws (listed at page 12) and check that the screws are fully seated (ensure that the screw heads do not protrude from the inner surface of the acetabular shell).

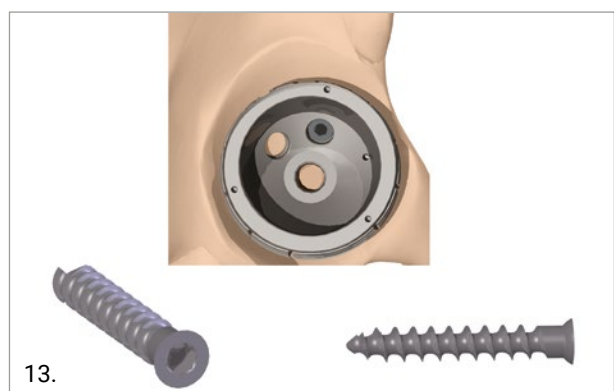

### TIP

It is possible to close the central hole with a metallic plug, which is packed together with the acetabular shell.

## 6. STABILITY TEST

During stability tests, the choice between a flat and a hooded liner can be made according to the surgeon's choice.



14.

Clean the interior surface of the acetabular shell. Assemble the multifunction handle with the trial liner corresponding to the acetabular shell size and femoral

head diameter (liners with interior diameter of 36 mm are available only for flat UHMWPE Highcross versions). Position the assembly in the acetabular shell. Unscrew the multifunction handle and reduce the hip in order to test the joint stability and limb length. After checking and testing mobility, joint stability and lower limb length, remove the trial liner with the aid of the multifunction handle.

### TIP

In case of hooded trial liner, use electrocautery to mark the satisfactory position of the hood.

### WARNING

Tests of stability must be performed with trial heads and not with definitive heads. The head sizes XL (for  $\varnothing$  28 mm,  $\varnothing$  32 mm) and XXL (for  $\varnothing$  28 mm,  $\varnothing$  32 mm,  $\varnothing$  36 mm) have a collar. This may decrease the Range of Motion in comparison to smaller sizes. Always perform trial reduction with the chosen head size.

## 7. POSITIONING OF DEFINITIVE LINER

The definitive liner must be chosen following the specific letter encoding; the internal diameter of the liner will be the same as the head chosen.

Before inserting the liner clean the interior surface of the acetabular shell, carefully remove any bone debris and tissue residues to avoid damage that could compromise the mechanical bearing.

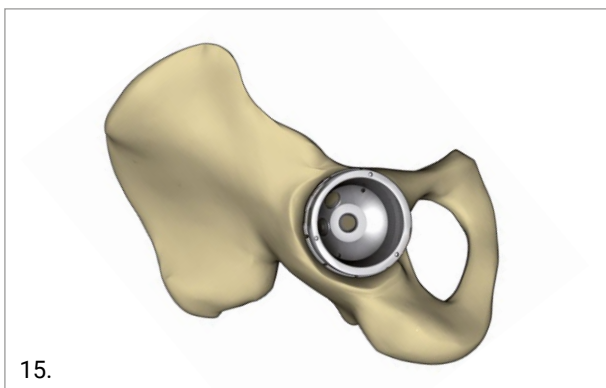

15.

### 7.1 POSITIONING OF THE DEFINITIVE UHMWPE LINER

To perform the UHMWPE liner positioning, impaction sphere or impaction washer can be used.

#### IMPACTION SPHERE SYSTEM

By hand, carefully place the UHMWPE liner in the acetabular shell along its axis. Ensure the hooded liner is positioned in the correct location, as determined by the trial.

Check that the liner has been correctly positioned.

Once the liner is in the correct position, secure it by pushing it in with your thumb. To perform the final impaction, assemble the impaction sphere (of the correct head size) on the multifunction straight impactor.

It is recommended, to facilitate proper assembly of the liner, to choose the largest fitting impaction sphere.

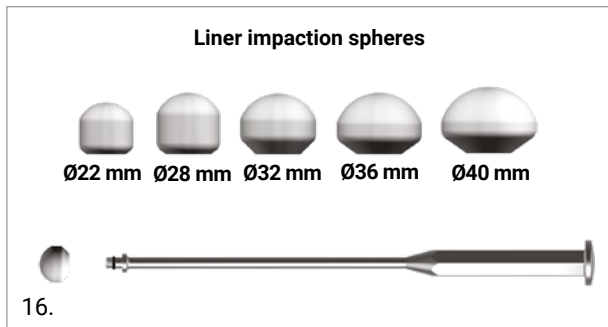

Insert the sphere into the UHMWPE liner and impact it using a hammer, until completely fixed. Remove the multifunction handle with the liner impactation sphere.

**WARNING**

Impactation should follow the "axis" of the cup, i.e. should be in a direction perpendicular to the plane of the equator. In order to do so, the offset AMIS impactor may facilitate negotiating soft tissues when an AMIS approach is being performed.

**TIP**

In order to ensure the correct placement of flat liner and the flat part of the hooded liner, check that the outside rim of the acetabular shell is exactly aligned with the outside rim of the liner.

Position the definitive head and reduce the hip.

**IMPACTION WASHER SYSTEM**

Assemble the definitive UHMWPE liner on the multifunction handle always together with the impactation washer for the fixed liner corresponding to the head diameter and type of liner chosen.

Position the assembly in the acetabular shell.

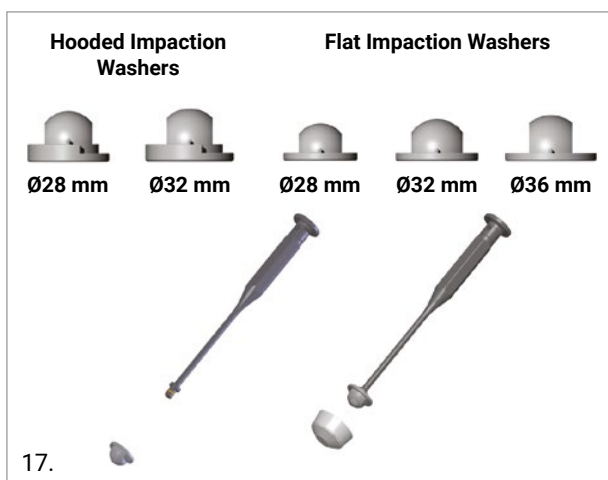

**CAUTION**

Sizes 22/AZ and 28/B UHMWPE Standard and Highcross and sizes 32/C and 36/E UHMWPE Highcross liners cannot be impacted with impactation washers. In order to perform a final impactation assemble the liner impactation sphere of correct diameter with the multifunction handle. Insert the sphere into the liner and fix the liner into place by exerting a hammer stroke in the axial direction.

The hooded liner raise orientation can be performed with the aid of: markings on the acetabular shell at 11h00, at 12h00 and at 13h00, a laser marking on the impactation washer at 12h00 and finally, a mark made during the test with hooded trial liner.

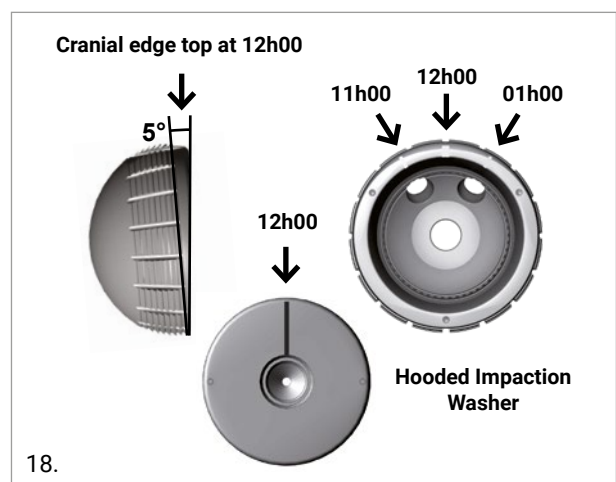

Impact the UHMWPE liner with the aid of a hammer, until completely fixed.

Remove the multifunction handle with its impactation washer.

**WARNING**

Impactation should follow the "axis" of the cup, i.e. should be in a direction perpendicular to the plane of the equator. In order to do so, the offset AMIS impactor may facilitate negotiating soft tissues when an AMIS approach is being performed.

**TIP**

In order to ensure the correct placement of flat liner and the flat part of the hooded liner, check that the outside rim of the acetabular shell is exactly aligned with the outside rim of the liner.

**OPTION**

It is possible to use the release key for the washer in order to unlock the impactation washer from the multifunction handle.

Position the definitive head and reduce the hip.

## 7.2 POSITIONING OF THE DEFINITIVE CERAMIC LINER

Carefully, manually place ceramic liner in the acetabular shell axis. A suction cap is available to manipulate ceramic liners without touching them.

Check whether the liner has been positioned correctly.

### TIP

In order to ensure the correct placement of the ceramic liners press the liner with your finger to be sure that it is seated correctly and that the outside rim of the acetabular shell is exactly aligned with the outside rim of the liner.

### CAUTION

It is not advised to implant a ceramic liner if the cup placement is too vertical, e.g. if the inclination is greater than 45°.

### CAUTION

In case of incorrect positioning of the ceramic liner, remove the liner with the blue suction cap and reposition it properly.

Once the liner is in the correct position, secure it by pushing it in with your thumb. To perform the final impaction, assemble the impaction sphere (of the correct head size) on the multifunction straight impactor.

It is recommended, to facilitate proper assembly of the liner, to choose the largest fitting impaction sphere.

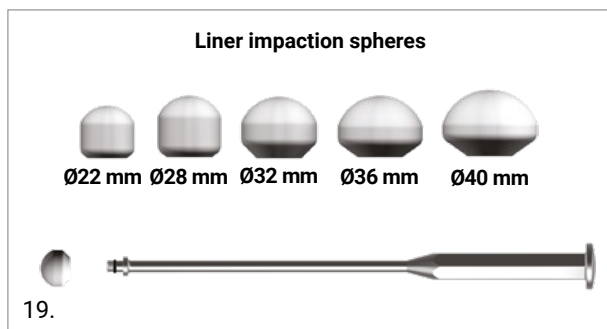

Insert the sphere into the UHMWPE liner and impact it using a hammer, until completely fixed. Remove the multifunction handle with the liner impaction sphere.

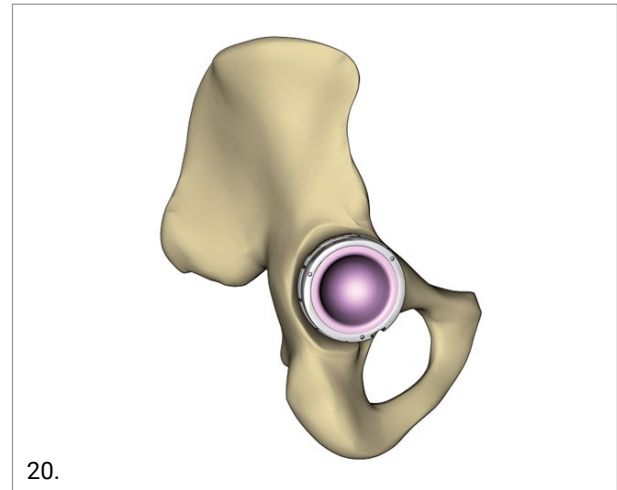

### WARNING

Impaction should follow the "axis" of the cup, i.e. should be in a direction perpendicular to the plane of the equator. In order to do so, the offset AMIS impactor may facilitate negotiating soft tissues when an AMIS approach is being performed.

### CAUTION

Never bring a metal hammer in contact with a ceramic liner.

Position the final ceramic head and reduce the hip.

## 8. IMPLANTS NOMENCLATURE

### VERSAFITCUP CC TRIO ACETABULAR SHELL

DIAMETER (mm)	REF.	LINER SIZE
40	01.26.45.0040'	AZ
42	01.26.45.0042'	AZ
44	01.26.45.0044'	B
46	01.26.45.0046	C
48	01.26.45.0048	C
50	01.26.45.0050	E
52	01.26.45.0052	E
54	01.26.45.0054	E
56	01.26.45.0056	F
58	01.26.45.0058	F
60	01.26.45.0060	F
62	01.26.45.0062	G
64	01.26.45.0064	G

### CANCELLOUS BONE SCREWS (FLAT HEAD - Ø 6.5 mm)\*

LENGTH (mm)	REF.
20	01.26.65.20
25	01.26.65.25
30	01.26.65.30
35	01.26.65.35
40	01.26.65.40
45	01.26.65.45

' On demand

\* For further details, please see page 8

### ACETABULAR SHELL CENTRAL PLUG

DESCRIPTION	REF.
Plug	01.26.45.0070

### VERSAFITCUP CC TRIO NO-HOLE ACETABULAR SHELL

DIAMETER (mm)	REF.	LINER SIZE
44	01.26.45.1144'	B
46	01.26.45.1146	C
48	01.26.45.1148	C
50	01.26.45.1150	E
52	01.26.45.1152	E
54	01.26.45.1154	E
56	01.26.45.1156	F
58	01.26.45.1158	F
60	01.26.45.1160	F
62	01.26.45.1162	G
64	01.26.45.1164	G

### CANCELLOUS BONE SCREWS Ø 6.5 mm\*

LENGTH (mm)	REF.
15	01.43.0015
20	01.43.0020
25	01.43.0025
30	01.43.0030
35	01.43.0035
40	01.43.0040
45	01.43.0045
50	01.43.0050"
55	01.43.0055"
60	01.43.0060"
65	01.43.0065"
70	01.43.0070"

" Availability upon approved special request only

### UHMWPE FLAT LINER

LINER SIZE	HEAD Ø 22	HEAD Ø 28	Head Ø 32
AZ	01.26.2233STT'	-	-
B	-	01.26.2837STT'	-
C	-	01.26.2839STT	-
E	-	01.26.2844STT	01.26.3244STT
F	-	01.26.2848STT	01.26.3248STT
G	-	01.26.2852STT	01.26.3252STT

### UHMWPE HOODED LINER

LINER SIZE	HEAD Ø 22	HEAD Ø 28	Head Ø 32
AZ	01.26.2233AT'	-	-
B	-	01.26.2837AT'	-
C	-	01.26.2839AT	-
E	-	01.26.2844AT	01.26.3244AT
F	-	01.26.2848AT	01.26.3248AT
G	-	01.26.2852AT	01.26.3252AT

### HIGHCROSS UHMWPE FLAT LINER

LINER SIZE	HEAD Ø 22	HEAD Ø 28	Head Ø 32	Head Ø 36
AZ	01.26.2233HCT'	-	-	-
B	-	01.26.2837HCT'	-	-
C	-	01.26.2839HCT	01.26.3239HCT	-
E	-	01.26.2844HCT	01.26.3244HCT	01.26.3644HCT
F	-	01.26.2848HCT	01.26.3248HCT	01.26.3648HCT
G	-	01.26.2852HCT	01.26.3252HCT	01.26.3652HCT

### HIGHCROSS UHMWPE HOODED LINER

LINER SIZE	HEAD Ø 22	HEAD Ø 28	Head Ø 32
AZ	01.26.2233HCAT'	-	-
B	-	01.26.2837HCAT'	-
C	-	01.26.2839HCAT	-
E	-	01.26.2844HCAT	01.26.3244HCAT
F	-	01.26.2848HCAT	01.26.3248HCAT
G	-	01.26.2852HCAT	01.26.3252HCAT

### CERAMIC LINER

LINER SIZE	HEAD Ø 28	HEAD Ø 32	Head Ø 36	Head Ø 40
B	01.29.402'	-	-	-
C	01.29.403	01.29.408	-	-
E	01.29.405	01.29.410	01.29.413	-
F	01.29.406	01.29.411	01.29.414	01.29.416
G	01.29.407	01.29.412	01.29.415	01.29.417

' On demand



Part numbers subject to change.

## **NOTE FOR STERILIZATION**

The instrumentation is not sterile upon delivery. Instruments must be cleaned before use and sterilized in an autoclave in accordance with the regulations of the country, EU directives where applicable, and following the instructions for use of the autoclave manufacturer. For detailed instructions, please refer to the document "Recommendations for cleaning, decontamination and sterilization of Medacta International orthopaedic devices" available at [www.medacta.com](http://www.medacta.com).



---

**REDEFINING BETTER  
IN ORTHOPAEDICS  
AND SPINE SURGERY**

---

MEDACTA.COM



**Medacta International SA**

Strada Regina, 34 - 6874 Castel San Pietro - Switzerland  
Phone +41 91 696 60 60 - Fax +41 91 696 60 66  
info@medacta.ch

Find your local dealer at: [medacta.com/locations](https://medacta.com/locations)

All trademarks are property of their respective owners and are registered at least in Switzerland.  
This document is not intended for the US market.  
Please verify approval of the devices described in this document with your local Medacta representative.

Not all products are currently available/standard in all countries.

Versafitcup® CC Trio  
Surgical Technique

ref: 99.16TRIO.12  
rev. 03

Last update: May 2022  
**CE 0476**